



# Hydra-Clean® Packages Pressure Washers

- Supply packages include everything you need for use with open head universal drums
- Available with an accumulator and chemical injector
- Configurations available to fit most pressure, flow, and material requirements
- Supports multiple guns
- Use with cold or hot water up to 200°F (93°C)

**Multiple Gun  
Industrial  
Cleaning  
Applications**



226-314 Bulldog 10:1 Cart Mount



206-515 President 10:1 Open Drum Mount

Graco's Hydra-Clean packaged systems are ideal for large cleaning applications where multiple guns and portability are required. These air-powered packages are ideal for routine cleaning chores with minimal air consumption in in-plant cleaning applications. The siphon tube is designed to hang on the edge of an open head universal drum. The pump works on demand for low wear and high efficiency; no unloader is required.

### Typical Fluids Handled

- Water
- Detergent solutions
- Chemical solutions

### Typical Applications

- Vehicle fleets, buses, transit systems
- Heavy construction equipment, off-highway vehicles
- General industrial equipment
- Building exteriors
- Sanitizing
- Public Works facilities and equipment
- Farm maintenance
- Marinas

# Technical Specifications for Hydra-Clean Packages

Pump Package	Max. Working Pressure psi (MPa, bar)	Max. Air Input Pressure psi (MPa, bar)	Fluid Flow at 60 cpm gpm (lpm)	Vol. per Cycle oz (cc)	Air Inlet Size	Fluid Inlet Size	Fluid Outlet Size	Package Instruction Manual
Monark 5:1	600 (41.4, 41.4)	120 (0.83, 8.3)	2.5 (9.46)	5.3 (156.7)	3/8 npt(f)	3/4 npt(f)	1/2 npt(f)	306-993
President 10:1	1800 (12.5, 125)	180 (1.25, 12.5)	3 gpm (11.4)	6.4 (189)	1/2 npt(f)	3/4 npt(f)	1/2 npt(f)	306-817
Bulldog 10:1	1200 (8.3, 83)	100 (0.7, 7)	9.2 (34.8)	19.6 (580)	3/4 npsm(f)	2 npt(f)	1-1/2 npt(m)	306-926, 308-509
King 20:1	1800 (12.5, 125)	90 (0.6, 6)	7.7 (29.1)	19.7 (582)	3/4 npsm(f)	2 npt(f)	1-1/2 npt(m)	308-509
Premier 34:1	3400 (23, 230)	100 (0.7, 7)	9.2 (34.8)	19.6 (580)	3/4 npsm(f)	2 npt(f)	1-1/2 npt(m)	-

## Performance Charts for Hydra-Clean Packages

Premier 34:1 Fluid Flow

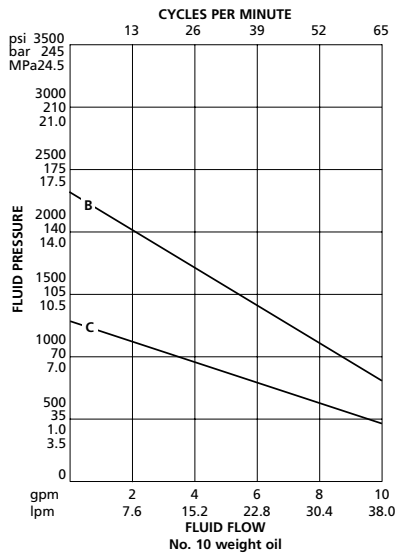

Premier 34:1 Air Consumption

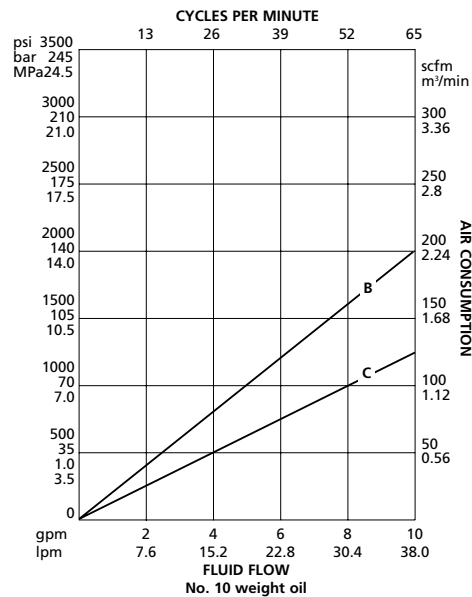

### Air Pressures

B = 100 psi (0.7 MPa, 7 bar)  
C = 70 psi (0.48 MPa, 4.8 bar)

# Performance Charts for Hydra-Clean Packages

**Monark 5:1 Fluid Flow**

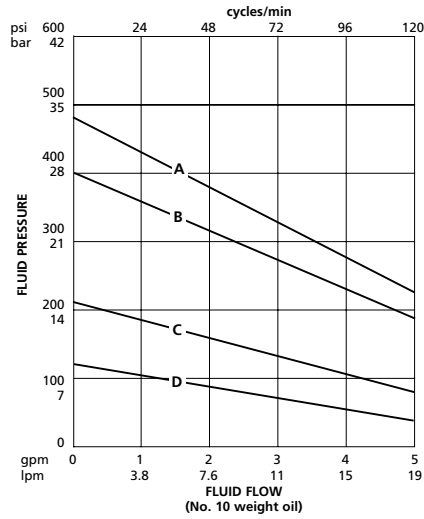

**Monark 5:1 Air Consumption**

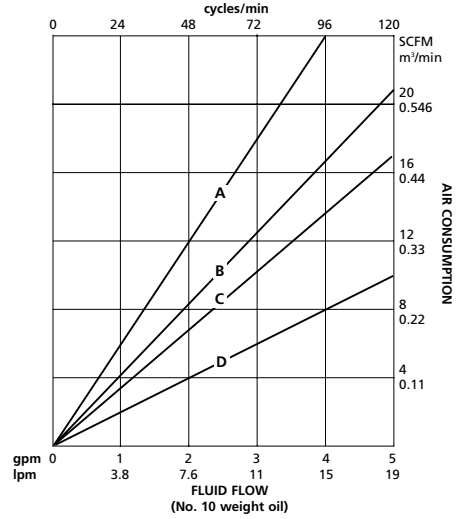

**President 10:1 Fluid Flow**

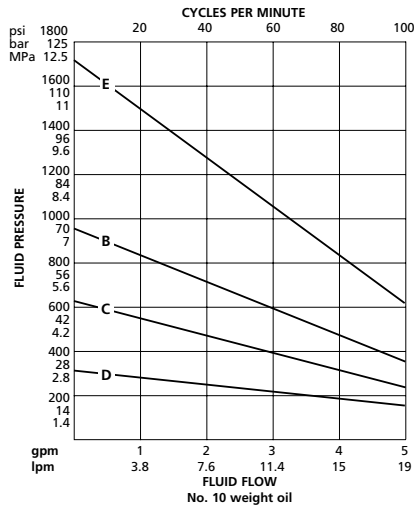

**President 10:1 Air Consumption**

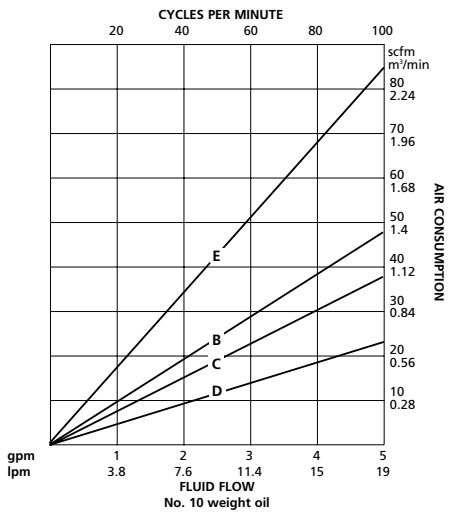

**Air Pressures**

- A = 120 psi (0.8 MPa, 8.1 bar)
- B = 100 psi (0.7 MPa, 7 bar)
- C = 70 psi (0.48 MPa, 4.8 bar)
- D = 40 psi (0.28 MPa, 2.8 bar)
- E = 180 psi (1.2 MPa, 12.2 bar)

# Performance Charts for Hydra-Clean Packages

**Bulldog 10:1 Fluid Flow**

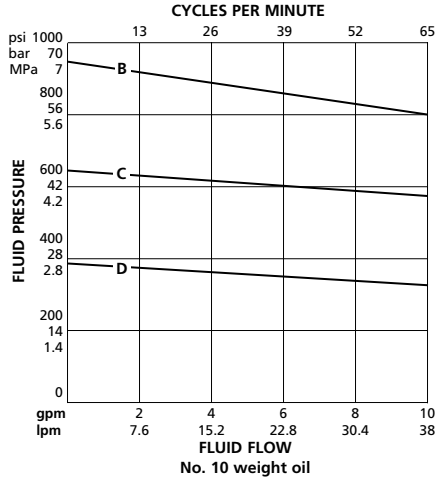

**Bulldog 10:1 Air Consumption**

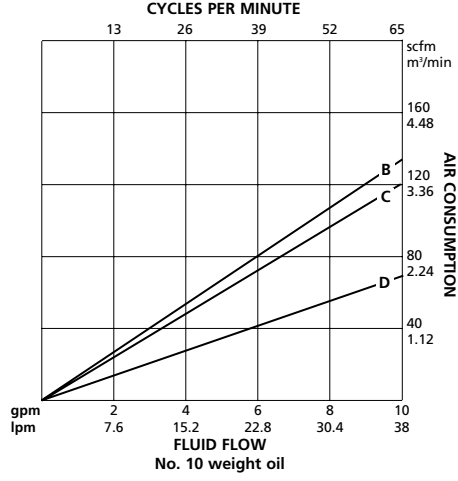

**King 20:1 Fluid Flow**

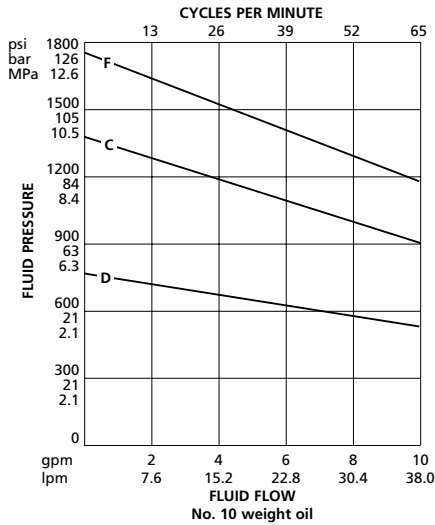

**King 20:1 Air Consumption**

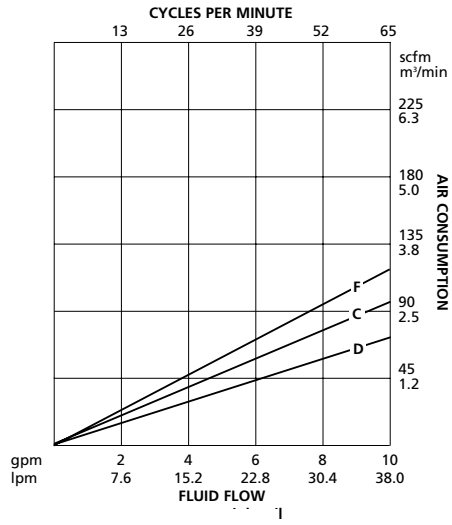

**Air Pressures**

- B = 100 psi (0.7 MPa, 7 bar)
- C = 70 psi (0.48 MPa, 4.8 bar)
- D = 40 psi (0.28 MPa, 2.8 bar)
- F = 90 psi (0.6 MPa, 6.1 bar)

# Dimensions for Hydra-Clean Packages

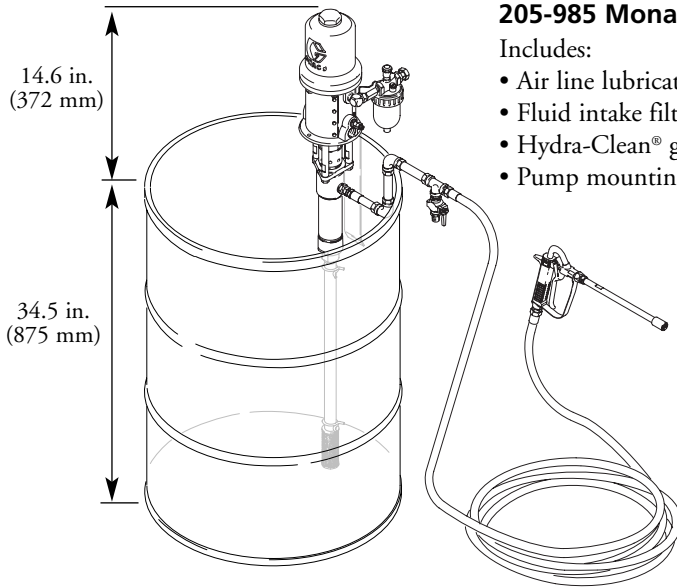

## 205-985 Monark 5:1 Open Drum Mount

Includes:

- Air line lubricator
- Fluid intake filter
- Hydra-Clean® gun and hose
- Pump mounting bracket

## 206-515 President 10:1 Open Drum Mount

Includes:

- Air line lubricator
- Fluid intake filter
- Hydra-Clean® gun and hose
- Fluid accumulator
- Pump mounting bracket

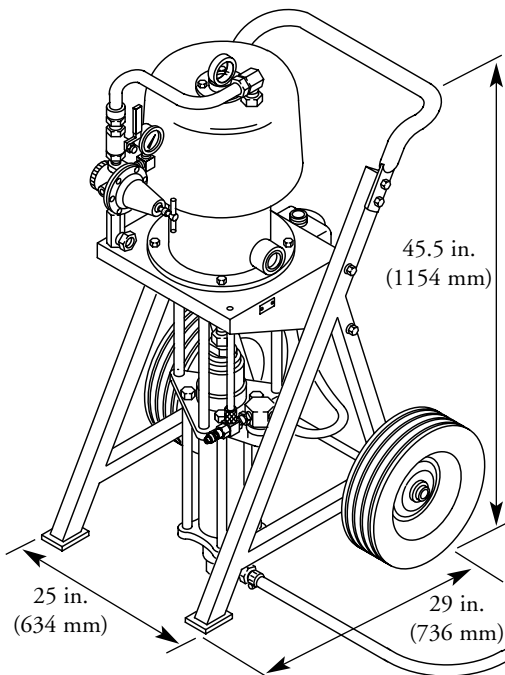
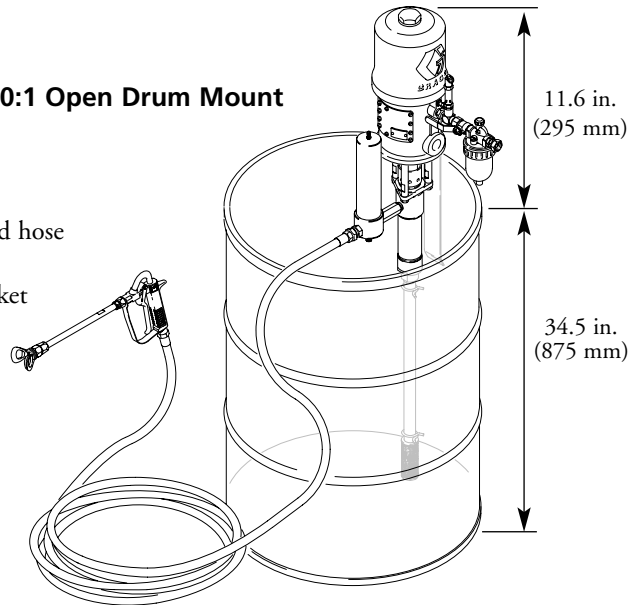

## 800-416 King 20:1 Standard Cart Mount

Includes:

- Air regulator
- Suction hose
- Hydra-Clean® gun and hose
- Fluid inlet filter
- Fluid accumulator
- Chemical strainer
- Chemical injector

## Dimensions for Hydra-Clean Packages

### 800-414 Bulldog 10:1 Standard Cart Mount

Includes:

- Air regulator
- Fluid inlet filter
- Fluid accumulator
- Hydra-Clean® gun and hose
- Suction hose
- Chemical strainer
- Chemical injector

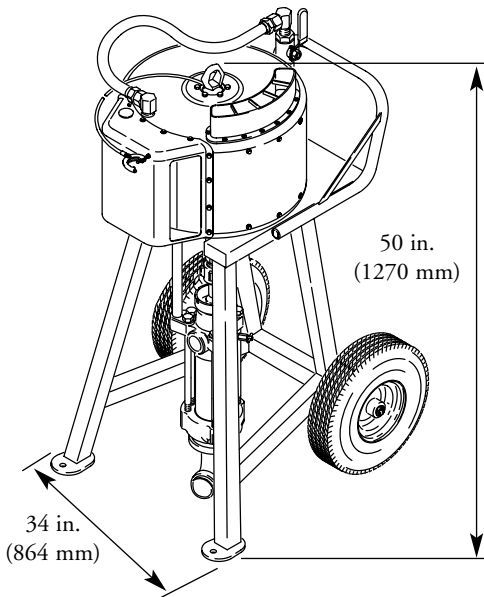
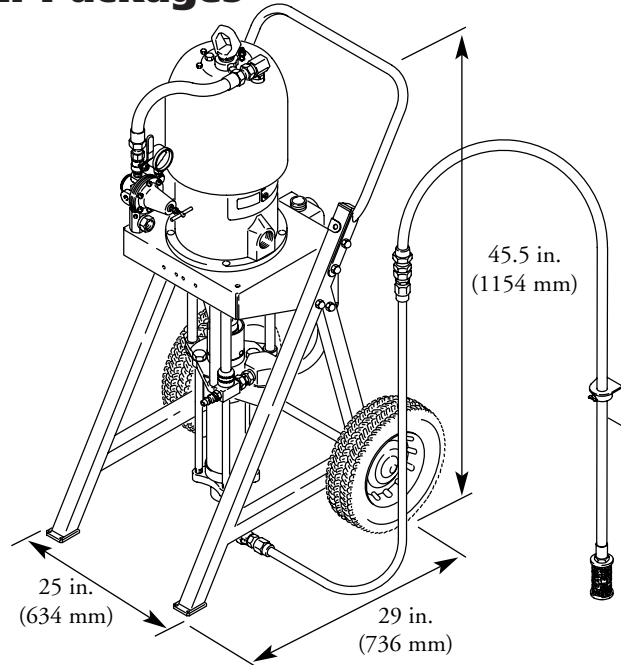

### 965-389 Premier 34:1 Heavy Duty Cart Mount

Includes:

- Air regulator
- Hydra-Clean® gun and hose

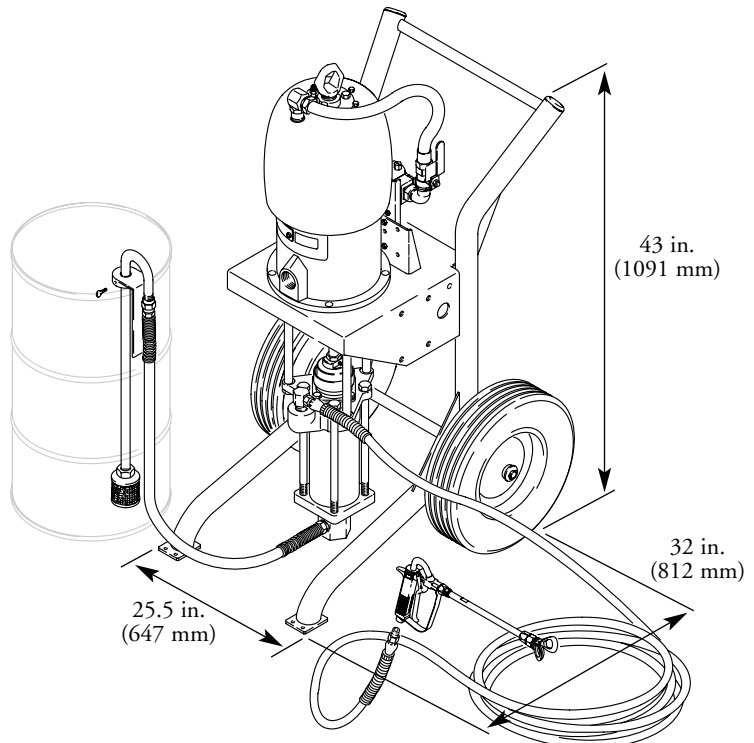

### 226-314 Bulldog 10:1 Heavy Duty Cart Mount

Includes:

- Air filter/regulator/lubricator
- Fluid intake filter
- Hydra-Clean® gun and hose
- Suction hose

# Ordering Information for Hydra-Clean Packages

	Monark 5:1	President 10:1	Bulldog 10:1	Bulldog 10:1	King 20:1	Premier 34:1
<b>Package Order Nos.</b>	<b>205-985</b>	<b>206-515</b>	<b>226-314</b>	<b>800-414</b>	<b>800-416</b>	<b>965-389</b>
<b>Pump Assembly Part No.</b>	224-345	224-346	206-797	215-875	951-803	
<b>Pump Lower Part No.</b>	224-344	224-344	206-792	206-792	902-169	222-994
<b>Construction</b>	SST	SST	SST	SST	SST	SST
<b>Standard Seal Repair Kits Construction</b>	224-402 UHMWPE/ Neoprene	224-402 UHMWPE/ Neoprene	207-581 Teflon	207-581 Teflon	946-682 Rubber	222-876 Teflon
<b>Optional Seal Repair Kits Construction</b>	224-404 UHMWPE/ Teflon	224-404 UHMWPE/ Teflon	N/A	N/A	N/A	222-875 UHMWPE/ Teflon
<b>Motor Repair Kit</b>	206-728	207-385	206-734	215-906	207-730	222-458

## SERVICE PARTS INFORMATION

<b>Pump Lower Part Nos.</b>	<b>224-344</b>	<b>224-344</b>	<b>206-792</b>	<b>206-792</b>	<b>902-169</b>	<b>222-994</b>
<b>Displacement Rod Construction</b>	186-997 SST	186-997 SST	206-614 SST	206-614 SST	206-614 SST	184-002 SST
<b>Cylinder Construction</b>	186-994 SST	186-994 SST	166-368 SST	166-368 SST	609-336 SST	184-003 SST
<b>Intake Valve (separate part numbers)</b>						
<b>Intake Ball</b>	101-917	101-917	101-968	101-968	101-968	110-294
<b>Intake Valve Seat</b>	186-992	186-992	206-617	206-617	206-617	222-838
<b>Piston Valve (separate part numbers)</b>						
<b>Piston Ball</b>	101-917	101-917	101-968	101-968	101-968	109-220
<b>Seat</b>	186-993	186-993	206-616	206-616	902-167	222-802
<b>Ball Guide</b>	176-644	N/A	N/A	N/A	166-371	184-297

Teflon® is a registered trademark of Du Pont.

## Accessories

### Bleed-Type Master Air Valve

Maximum working pressure: 300 psi (2.1 MPa, 21 bar)

**107-141** Inlet: 3/4 npt(m); outlet: 3/4 npt(f).

**107-142** Inlet: 1/2 npt(m); outlet: 1/2 npt(f).

### Air Line Filter

Maximum working pressure: 250 psi (1.8 MPa, 18 bar)

**106-149** Inlet and outlet: 1/2 npt(f).

**106-150** Inlet and outlet: 3/4 npt(f).

### Air Line Lubricator

Maximum working pressure: 250 psi (1.8 MPa, 18 bar)

**214-849** Inlet and outlet: 3/4 npt(f).

**214-848** Inlet and outlet: 1/2 npt(f).

### 207-651 Air Pressure Regulator Kit

Maximum working pressure: 300 psi (2.1 MPa, 21 bar).

### 104-266 Air Regulator

Maximum working pressure: 300 psi (2.1 MPa, 21 bar).

Inlet and outlet: 1/2 pt(f).

### 224-040 Pump Runaway Valve

Maximum working pressure: 120 psi (0.8 MPa, 8.4 bar).

### 237-569 Ground Wire and Clamp

Length: 25 ft. (7.6 m), 12 gauge (1.5 mm<sup>2</sup>)

### Graco Throat Seal Liquid

**206-995** 1 quart (0.95 liter)

**206-996** 1 gallon (3.8 liter)

### 208-008 Spray Gun

Inlet: 3/8 npt(f).

### High Pressure Buna-N Fluid Hose

**205-753** Maximum working pressure: 2250 psi (15.3 MPa, 153 bar). 3/8 npt(mbe) x 40 ft. (12.1 m). SST coupling.

**205-174** Maximum working pressure: 1250 psi (8.6 MPa, 86 bar). 1/4 npt(mbe) x 40 ft. (12.1 m). CS coupling.

### Grounded Buna-N Air Hose

Maximum working pressure: 175 psi (1.2 MPa, 12 bar)

ID: 3/4 in. (19 mm); thread size 3/4 npt(m)

#### Part No. Length

**208-610** 6 ft. (1.8 m)

**205-548** 15 ft. (4.5 m)

**208-611** 25 ft. (7.6 m)

**208-612** 50 ft. (15.2 m)

### Grounded Buna-S Air Hose

Maximum working pressure: 175 psi (1.2 MPa, 12 bar)

1/2 in. ID (1.3 cm). 1/2 npt(m).

#### Part No. Length

**205-418** 6 ft. (1.8 m)

**205-273** 25 ft. (7.6 m)

**208-594** 50 ft. (15.2 m)

### Grounded Nylon Fluid Hose

Maximum working pressure: 3000 psi (21 MPa, 210 bar)

Part No.	ID	Length	Thread
<b>214-700</b>	3/16 in (5 mm)	2 ft (0.6 m)	1/4 npsm(fbe)
<b>214-701</b>	3/16 in (5 mm)	3 ft (0.9 m)	1/4 npsm(f) x 1/4 npt(m)
<b>223-540</b>	1/4 in (6.3 mm)	25 ft (7.6 m)	1/4 npsm(fbe)
<b>223-541</b>	1/4 in (6.3 mm)	50 ft (15.2 m)	1/4 npsm(fbe)
<b>214-703</b>	3/8 in (9.5 mm)	25 ft (7.6 m)	3/8 npt(mbe)
<b>214-705</b>	3/8 in (9.5 mm)	50 ft (15.2 m)	3/8 npt(mbe)
<b>214-920</b>	3/8 in (9.5 mm)	100 ft (30.4 m)	3/8 npt(mbe)

Maximum working pressure: 5000 psi (345 MPa, 345 bar)

**214-912** 1/4 in (6 mm) 3 ft (0.9 m) 1/4 npsm(f)

**214-914** 1/4 in (6.3 mm) 25 ft (7.67 m) 1/4 npsm(f)

**214-915** 1/4 in (6.3 mm) 50 ft (15.2 m) 1/4 npsm(f)

**215-244** 3/8 in (9.5 mm) 25 ft (7.6 m) 3/8 npt(m)

**238-396** 3/8 in (9.5 mm) 50 ft (15.2 m) 3/8 npt(m)